

경고 Warning 본 도면 및 디자인은 SSK (주)신세기산업의 기밀자산이며, SSK (주)신세기산업의 문서화 된 동의없이 어떠한 형식으로도 복제하거나 전송 할수 없습니다.
This Drawing & Design is Confidential Property of SSK CO., LTD. No part of it may be reproduced or transmitted in any form without documented consent of SSK CO., LTD.

NO.	DATE	REVISION	DRAWN
1	-	-	-
2			
3			

APPROVAL

DATE

SIGNATURE

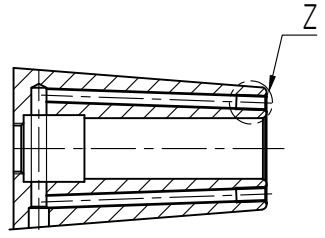
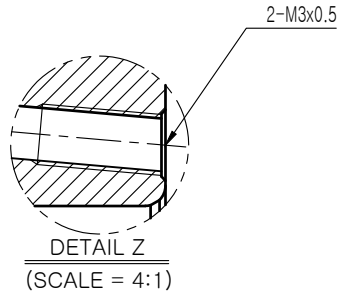

- NOTE**
1. ROUND R=1.0
 2. BREAK SHARP CONERS 0.5x45°
 3. ANGLES ±0°15'
 4. BALANCE : G2.5 / 25,000rpm

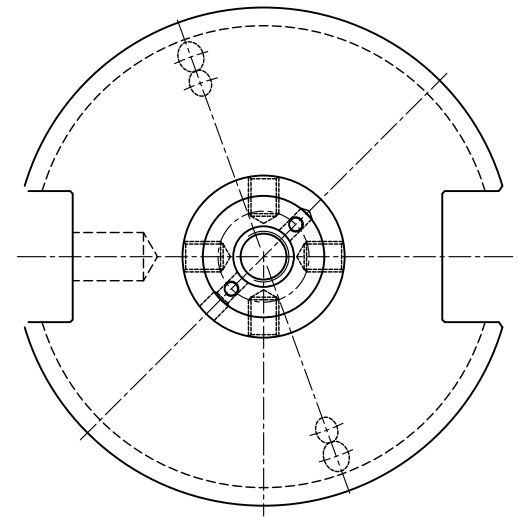
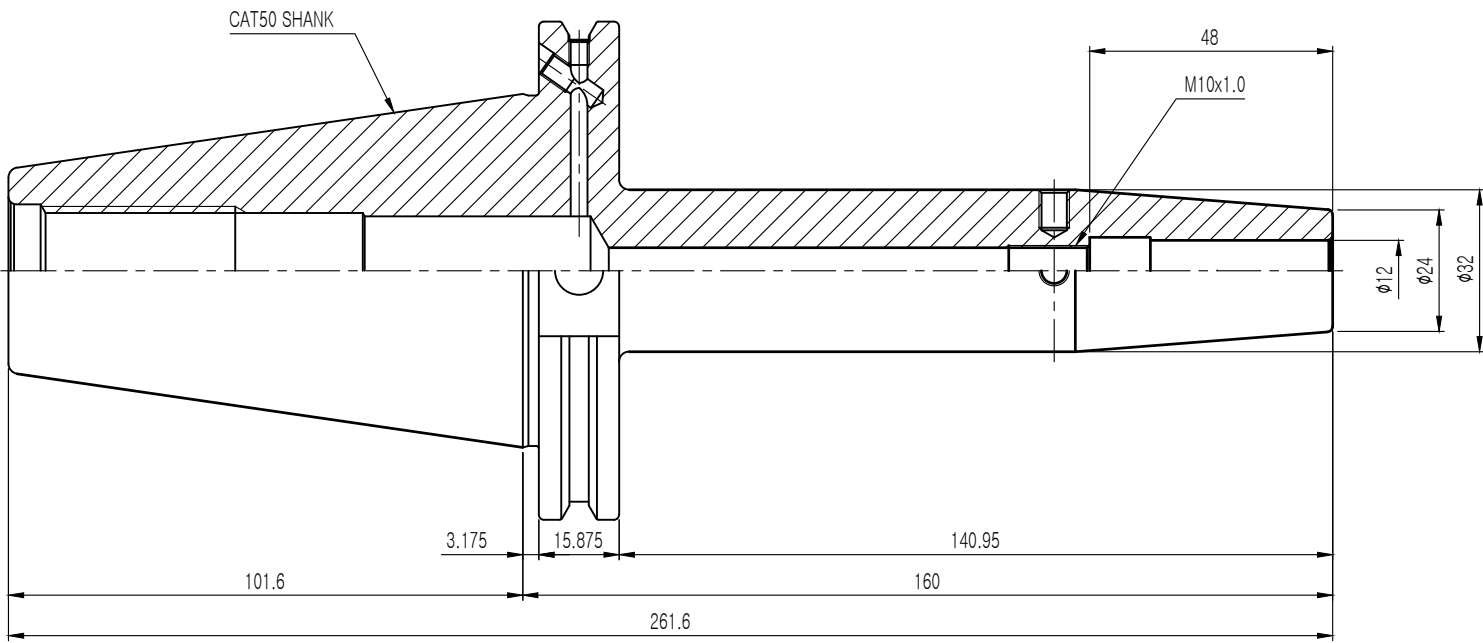

MATERIAL		REV No.	00	DATE	2023.02.20
MAT. SIZE		SURFACE TREATMENT			
HARDNESS	HRC	KIND	ASME B5.50 : 2009		
DESCRIPTION	SHRINK FIT HOLDER				
ORDER MAKER	SAB	OEM CODE			
SPEC.	CAT50AD/B-SFH20CR-160		TYPE	APPROVAL	

기호	Rmax	Ra	Rz	기	구분	1-50	50-100	100-250	250-500	DRAWN	CHECKED	CHECKED	APPROVED
~	✓	✓	-	차	내경	+0.1	+0.15	+0.25	+0.35	B.H.S			
▽	✓	25/✓	100S	면	외경	-0	-0	-0	-0				
▽▽	✓	6.3/✓	25S	조	전장	+0	+0	+0	+0				
▽▽▽	✓	1.9/✓	6.3S	도	SCALE	±0.1	±0.15	±0.25	±0.35				
▽▽▽▽	✓	0.2/✓	0.8S		Dim.	1 : 1				SSK 신세기산업주식회사 SSK TOOL CO., LTD.			
					mm	mm							